

TECHNICAL DATA - TECHNISCHE DATEN
FICHE TECHNIQUE - DATOS TECNICOS - DATI TECNICI



CRANE - KRAN
GRUE - GRUA - GRU **530**

FERRARI

Manual extensions - Mech.Verlängerung
 Rallonges mecaniq. - Prolongas mecan.
 Prolunghe manuali

LOAD CURVES
 BELASTUNGDIAGRAMM
 DIAGRAMME DE CHARGE
 DIAGRAMA DE CARGAS
 CURVE DI CARICO

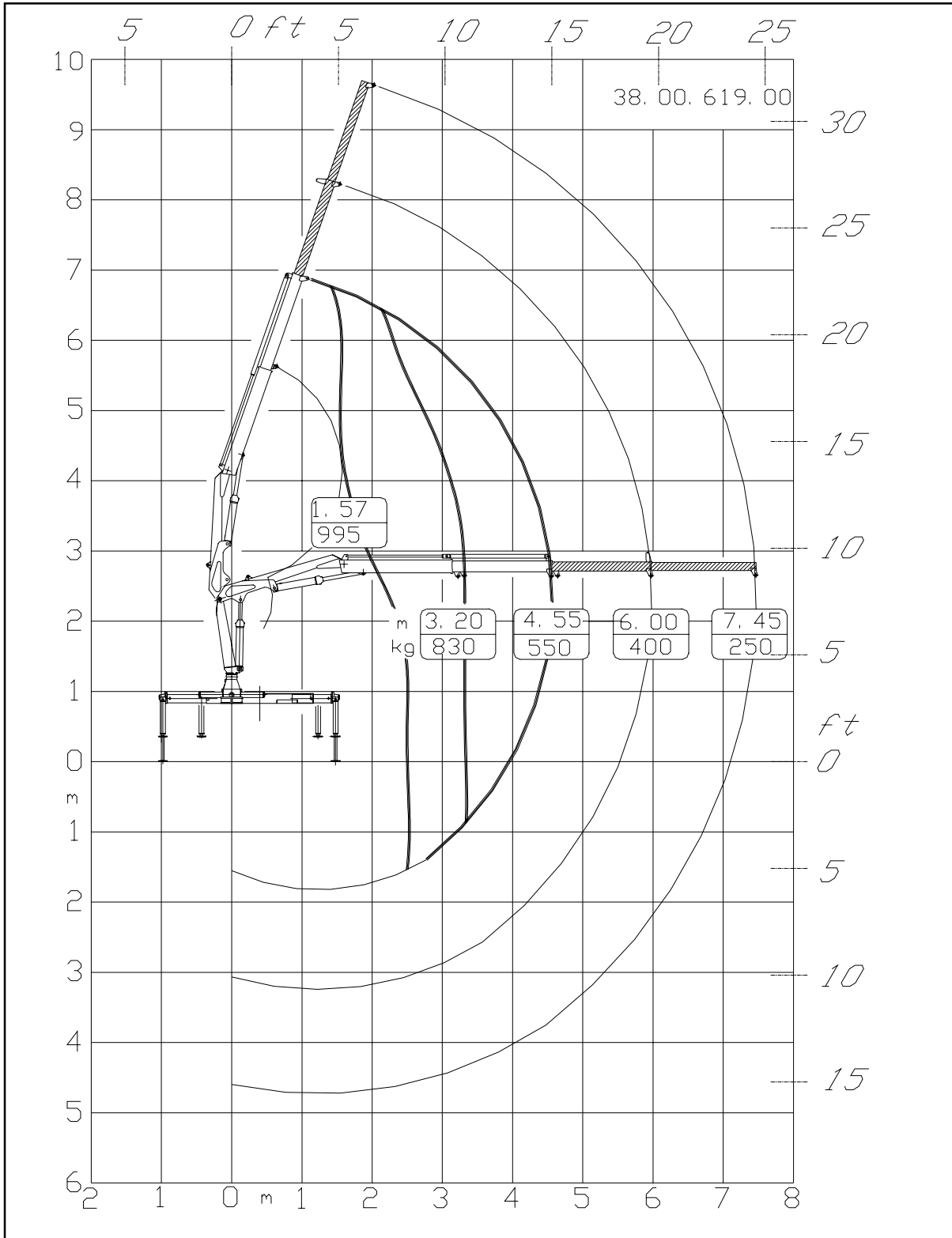

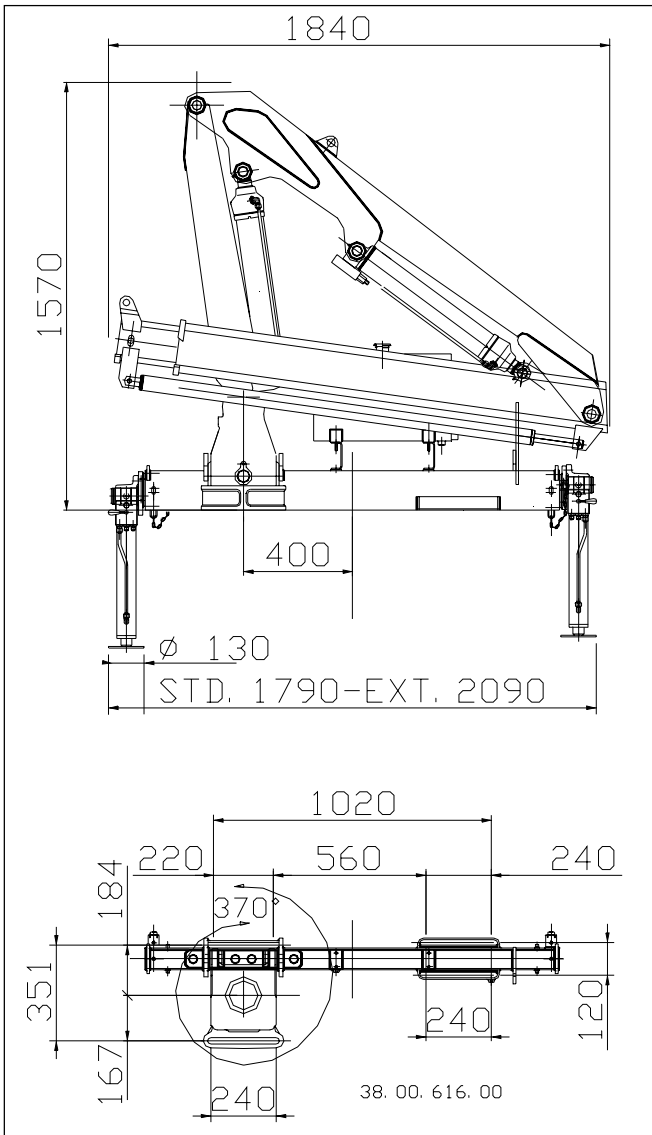
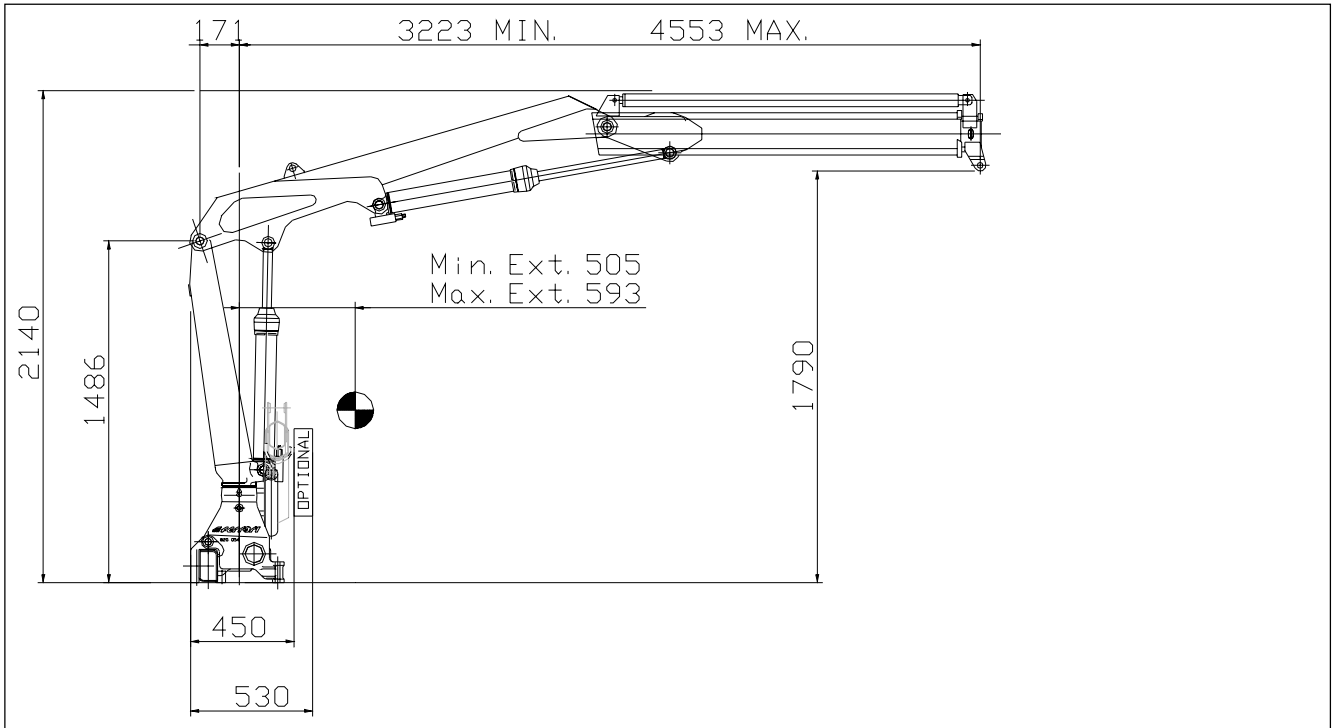

OVERALL DIMENSIONS
 AUSSENMASSE
 COTES D'ENCOMBREMENT
 DIMENSIONES
 DIMENSIONI DI INGOMBRO

Manual extensions - Mech.Verlangerung
 Rallonges mecaniq. - Prolongas mecan.
 Prolunghe manuali

LOAD CURVES
 BELASTUNGDIAGRAMM
 DIAGRAMME DE CHARGE
 DIAGRAMA DE CARGAS
 CURVE DI CARICO

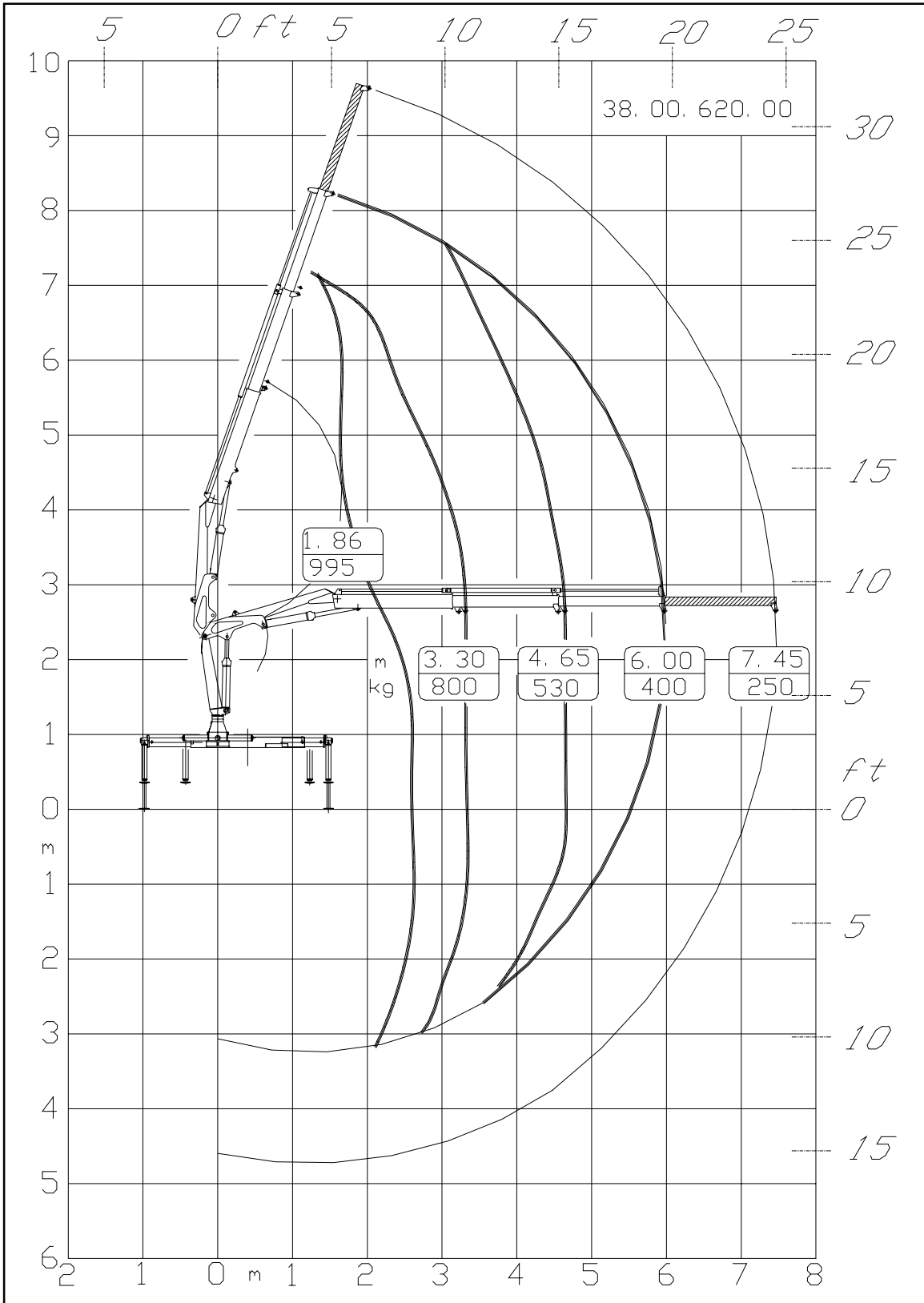

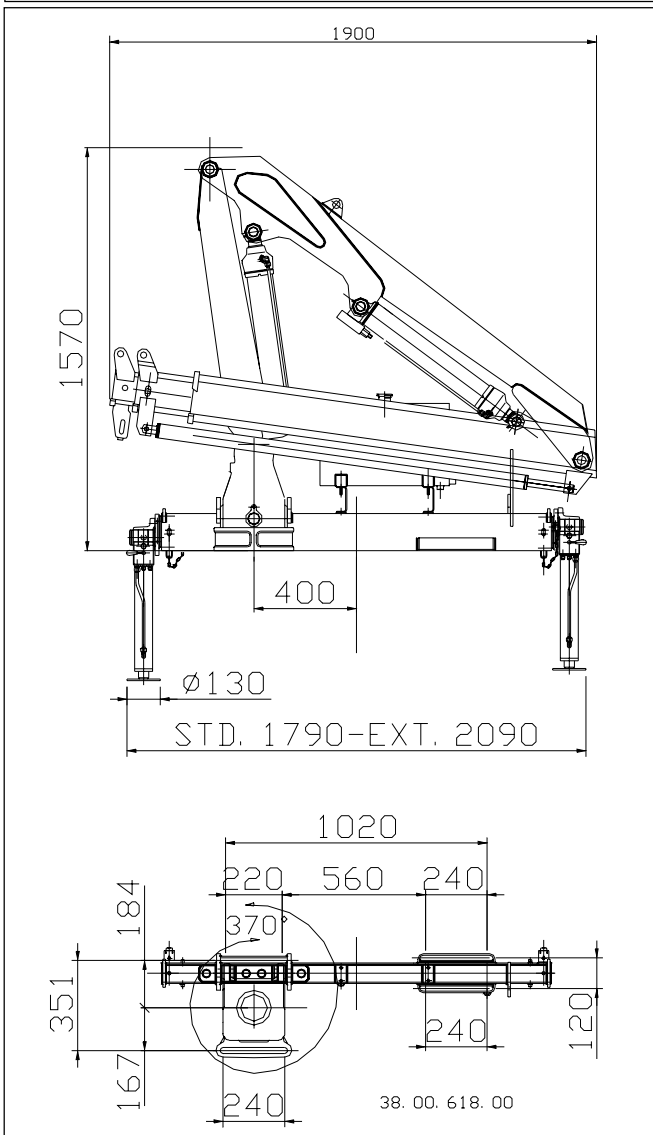
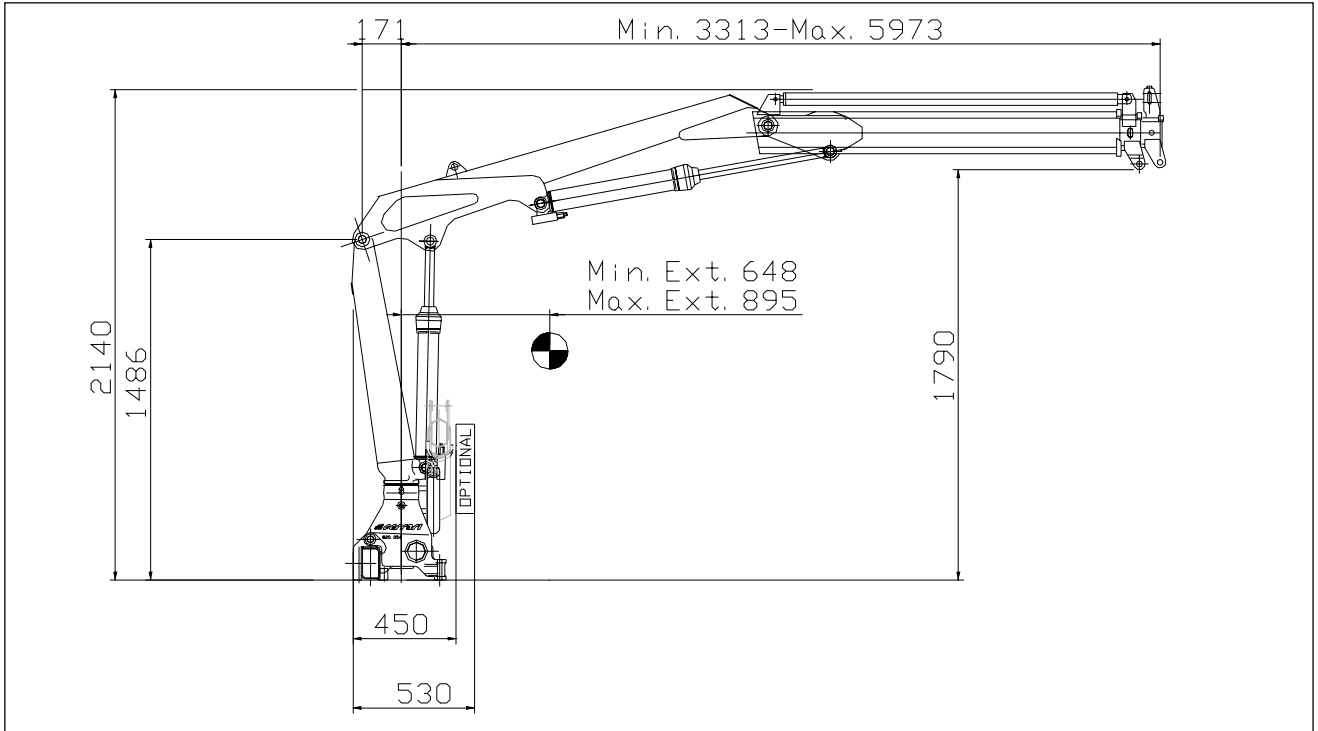

OVERALL DIMENSIONS
 AUSSENMASSE
 COTES D'ENCOMBREMENT
 DIMENSIONES
 DIMENSIONI DI INGOMBRO

Manual extensions - Mech.Verlangerung
 Rallonges mecaniq. - Prolongas mecan.
 Prolunghe manuali

LOAD CURVES
 BELASTUNGDIAGRAMM
 DIAGRAMME DE CHARGE
 DIAGRAMA DE CARGAS
 CURVE DI CARICO

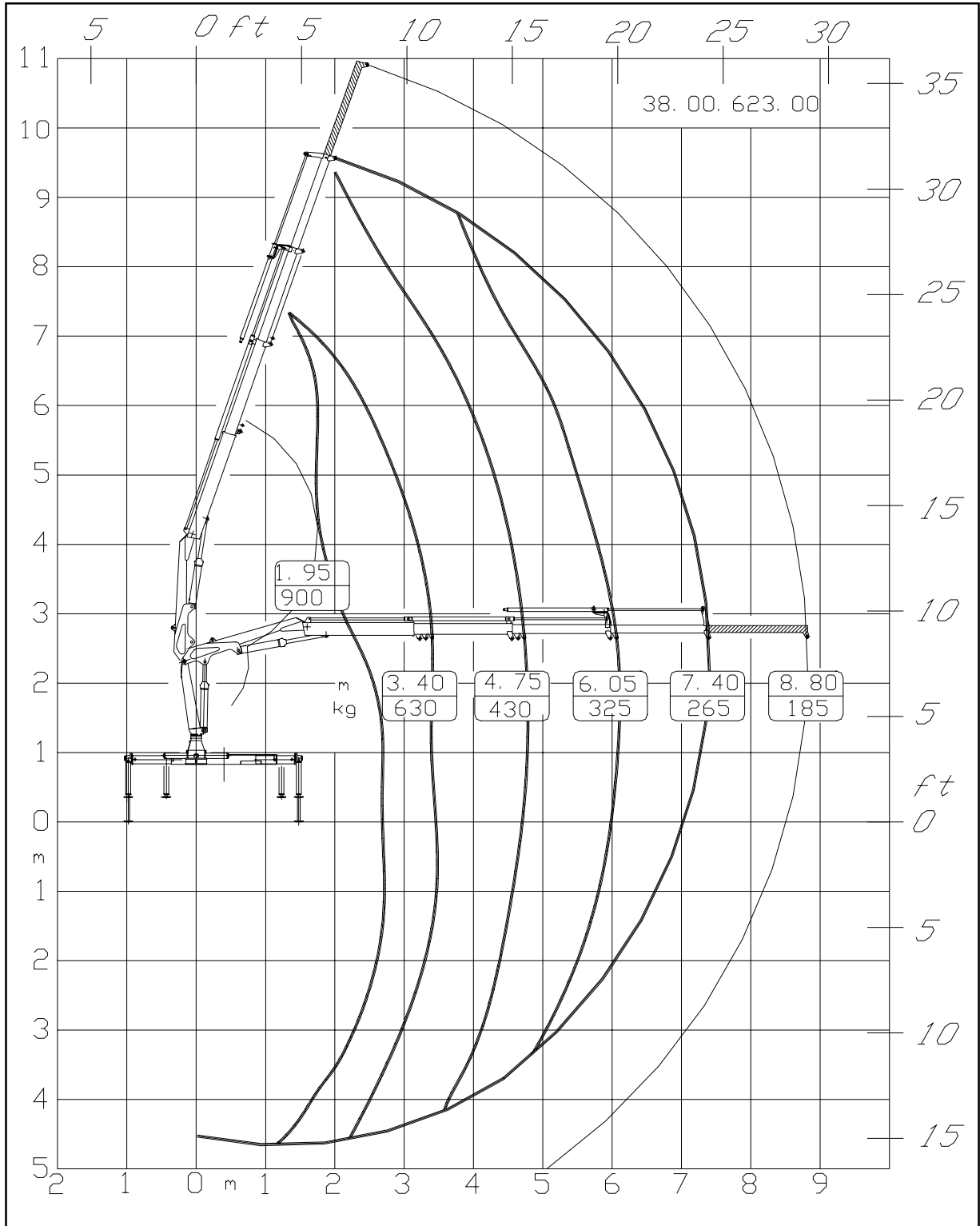

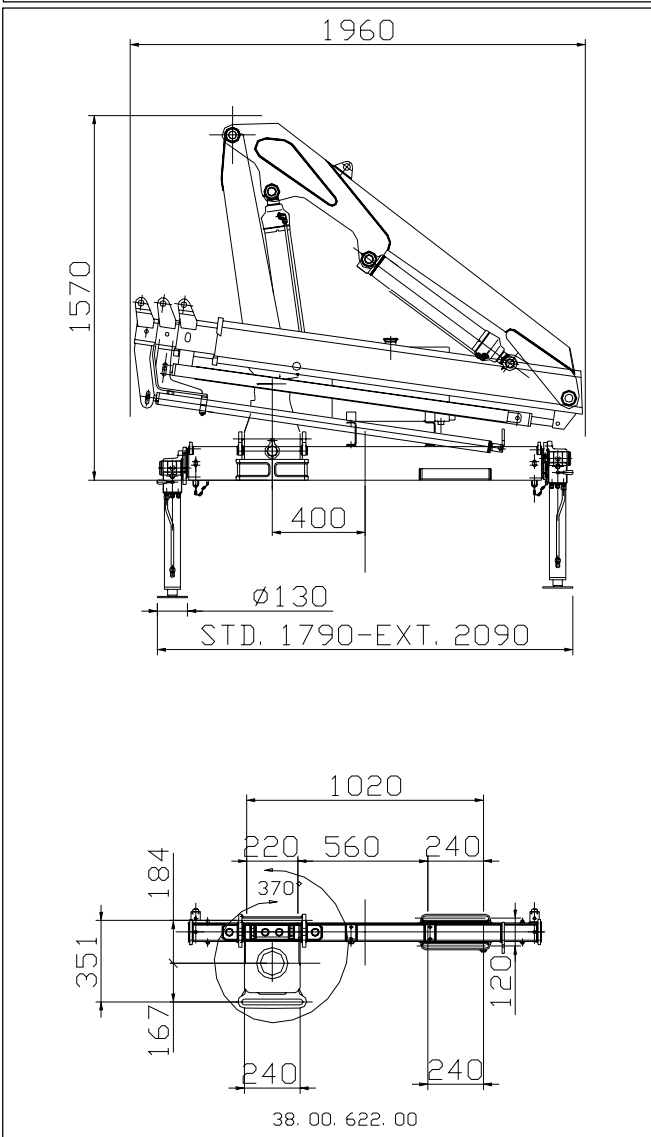
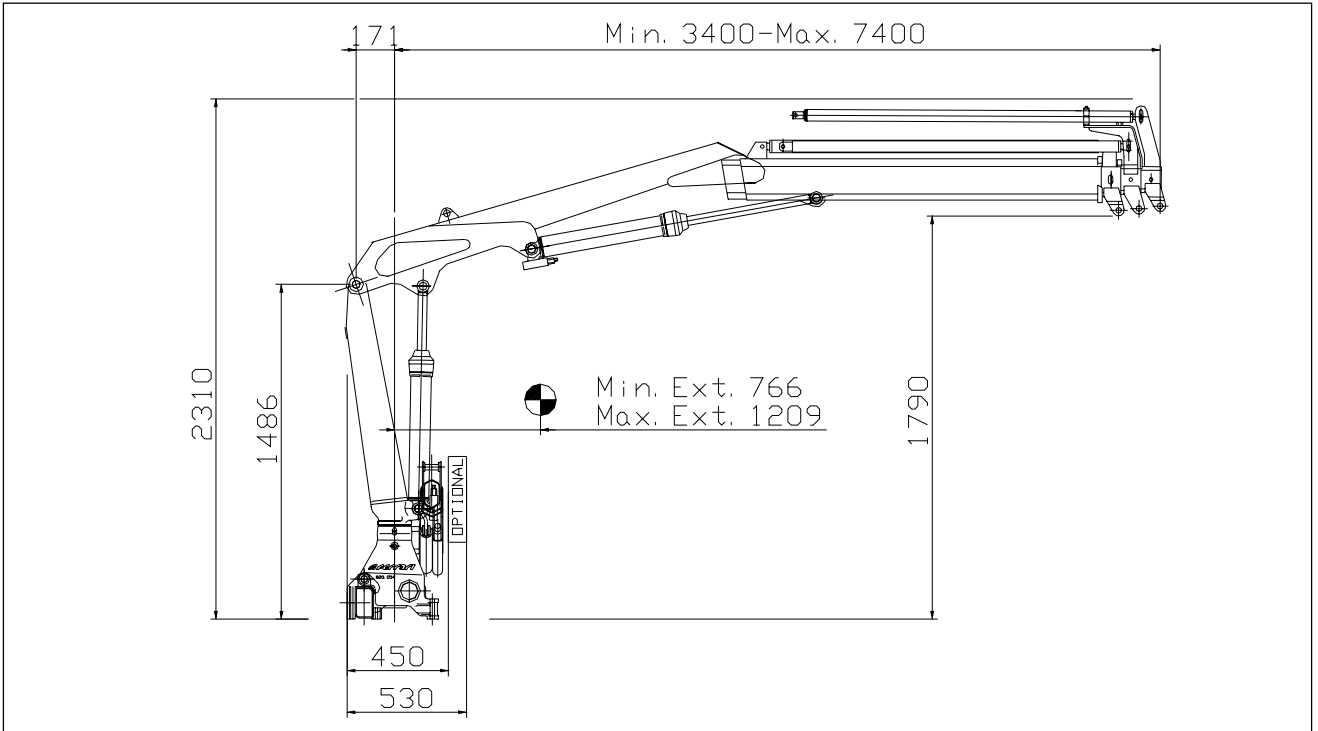

OVERALL DIMENSIONS
 AUSSENMASSE
 COTES D'ENCOMBREMENT
 DIMENSIONES
 DIMENSIONI DI INGOMBRO

TECNICAL DATA	TECNISCHE DATA	FICHE TECHIQUE	DATOS TECNICOS	DATI TECNICI
Lifting capacity max	Kapazitätsklasse max	Couple de levage, maximum	Capacidad de elevacion, maximo	Capacità Sollevamento
Hydraulic outreach standard	Standardausladung=hydraulisch	Portée hydraulique standard	Alcance hidraulico maximo	Estensione idraulica massima
Hydraulic boom extension	Ausladung hydraulisch Teleskopausschieber	Course de rallonge hydraulique	Carrera de la extension hidraul.	Escursione idraulica sfili
Outreach manual extension	Ausladung manual Armverlängerung	Portée avec rallonge manuelle	Alcance, extension manual	Estensione manuale massima
Lifting height above installation level, Hydraulic	Hubhöhe über KransockelHydr.	Hauteur de levage au-dessus du plan de pose, Hydr.	Altura de elevacion desde la base. Hifdraulica	Altezza carico dal controtelaio. Idraulica
max oil flow	Max Pumpeleistung	Debit max au distributeur	Alcance max al distribudor	Portata della pompa
max oil flow, PB	Max Pumpeleistung, PB	Debit max au distributeur, PB	Alcance max al distribudor, PB	Portata della pompa con PB inserito
Working pressure	Arbeitsdruck	Pression de travail	Presion de trabajo.	Pressione di lavoro
Power needed at recommended oil flow	Kraftbedarf bei empf.Ölfördermenge	Puissance requise au debit recommandée.	Potencia necesaria a caudal recomendado.	Potenza idraulica consigliata
Tank Capacity	Tankgröße	Capacité du réservoir	Volumen de aceite, deposito.	Capacità del serbatoio
Slewing Angle	Schwenkbereich	Angle de rotation	Angulo de giro	Angolo di rotazione massimo
Max.slope viable at full capacity	Max.Schragstellung bei max.Hubkraft	Angle possible pour couple de levage max.	Inclinacion posible a capacidad maxima	Inclinazione di lavoro massima a pieno carico
Rated slewing torque, gross	Bruttoschwenkmoment(Nennwert)	Couple de giration, brut theorique	Par de giro, bruto teorico	Coppia di rotazione nominale massima
Slewing speed	Schwenkgeschwindigkeit	Vitesse de rotation	Velocidad de giro	Velocità di rotazione
Hydraulic boom extension time out/in	Zeit für Teleskopbewegung Aus/Ein	Temps de manoeuvre du télescope, sortie/rentree	tiempo para recoger y extender la prolonga hidraulica	Tempo uscita e rientro sfili idraulici
Installation space needed	Einbauplatzbedarf	Espace de montage requis	Espacio de instalacion	Spazio richiesto per l'installazione
(With activations)	(Mit Aktivierungen)	(Avec activations)	(Activada)	(con attivazioni)
WEIGHTS	GEWICHTE	POIDS	PESO	PESI
Loader in standard version (crane+oil+installation kit+std stab.)	Kran in Standardausführung (Kran+Öl+Montagesatz+ Abstützungen in Standard Version)	Grue standard (grue+huile+kit de montage+bequilles standard)	Grua, modelo estandard(grua+aceite+kit instalacion+gatos estandard)	Peso della gru standard base(gru+olio+staff.+stab .stand.)
Frame attachments	Brieden	Fixation	Esparragos de sujecion	Peso Kit ancoraggio
Oil intank	Tankinhalt	Huile dans reservoir	Aceite del deposito	Peso olio nel serbatoio
manual std outriggers	standard manuelle Abstützungen	Stabilisateurs std manuels	Equipo de gatos Estandard manual	Peso stabilizzatori Standard manuali
hydraulic std outriggers	standard hydraulische Abstützungen	Stabilisateurs std hydraulique	Equipo de gatos estandard hidraulico	Peso stabilizzatori standard Idraulici
manual extraoutriggers	extrabreite manuelle Abstützungen	Stabilisateurs extra extensibles manuels	Equipo de gatos extraestensibles manual	Peso stabilizzatori Extra manuali
hydraulic extraoutriggers	extrabreite hydraulische Abstützungen	Stabilisateurs extra extensibles hydraulique	Equipo de gatos extraestensibles hidraulico	Peso stabilizzatori extra Idraulici
manual XXL outriggers	superbreite (XXL) manuelle Abstützungen	Stabilisateurs XXL manuels	Equipo de gatos XXL manual	peso stabilizzatori XXL manuali
hidraulic XXL outriggers	superbreite (XXL) hydraulische Abstützungen	Stabilisateurs XXL hydraulique	Equipo de gatos XXL hidraulico	peso stabilizzatori XXL idraulici

530A1	530A2	530A3
2,65 Tm 26 KNm	2,64 Tm 26 KNm	2,1 Tm 21 KNm
4,55 m	6 m	7,4 m
1,35 m	2,7 m	4 m
7,45 m	7,45 m	8,8 m
6,05 m	7,4 m	8,74 m
10 l/min	10 l/min	10 l/min
170 Bar	170 Bar	165 Bar
2,8 KW	2,8 KW	2,8 KW
25 l	25 l	25 l
370 °	370 °	370 °
3 °	3 °	3 °
3,36 KNm	3,36 KNm	3,36 KNm
14 °/s	14 °/s	14 °/s
13" ; 9"	26" ; 14"	39" ; 21"
510 mm	510 mm	510 mm
590 mm	590 mm	590 mm
530A1	530A2	530A3
453 Kg	486 Kg	516 Kg
20 Kg	20 Kg	20 Kg
22 Kg	22 Kg	22 Kg
55 Kg	55 Kg	55 Kg
63 Kg	63 Kg	63 Kg

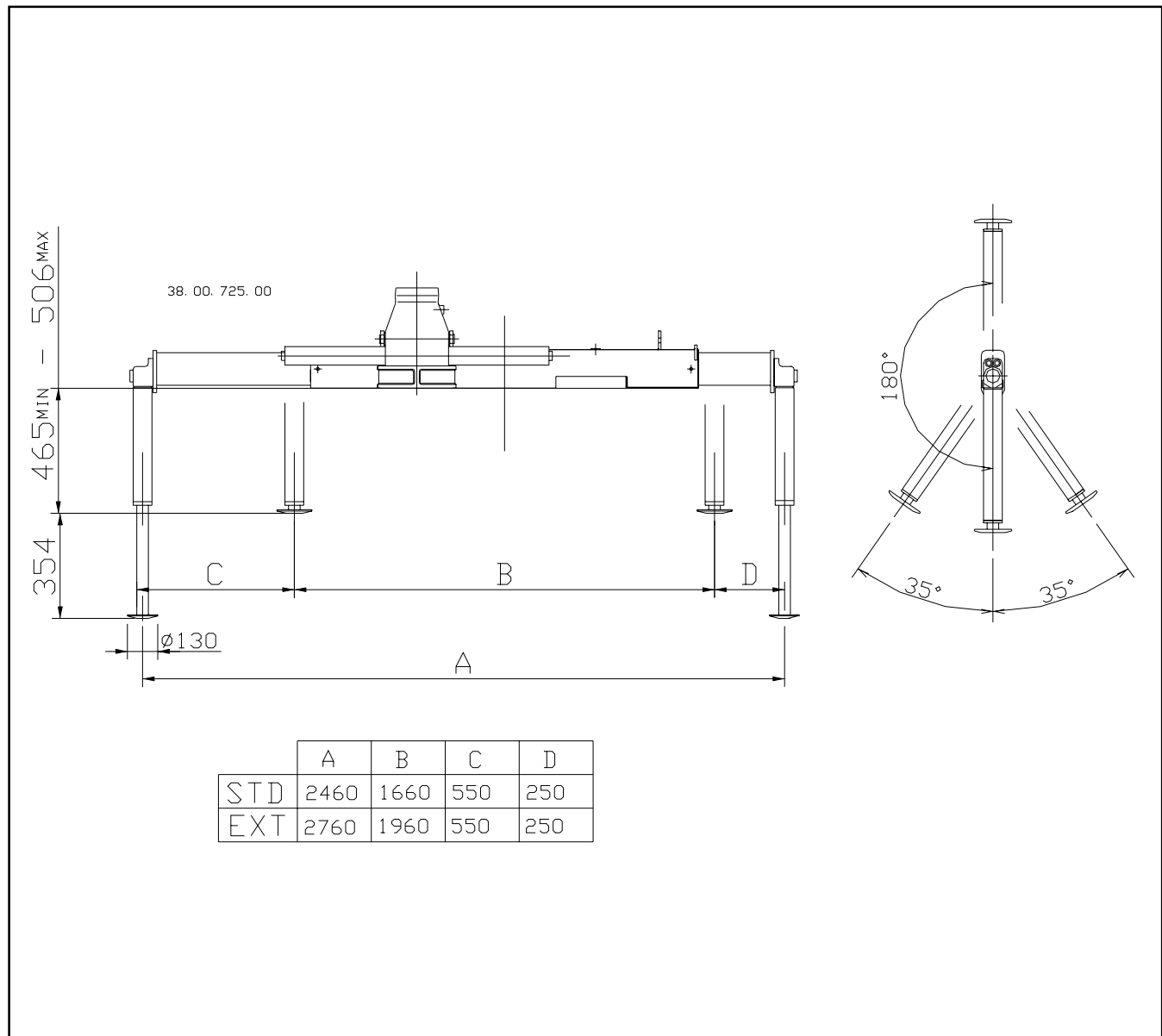

OPTIONALS



Stabilizzatori extraes.
Extra extend.outrigg.
Extra stabilizat.esten.
Extraverbr.stutzen
Estabiliz.extra exten.



Comando suppl.attiv.
Suppl.activ.element
Distr.suppl.active
Aktiviert elemente
Mando supl.activado



Com.suppl.non att.
Suppl.non activ.elem.
Distr.suppl.nonactive
Nicht aktiviert elem.
Mando supl.non act.



Verricello idraulico
Hydraulic winch
Treuil hidraulique
Winde
Cabrestante hidr.



Traversa suppl.estend.
Extra extend. beam
Traverse extra estens.
Drenbar-kreuzstange
Traviesa supl.extens.



Prolonghe meccan.
Mech. extension
Rallonges mecaniq.
Mech.verlangerung
Prolongas mecan.



Limitat. di momento
Overload device
Limiteur de charge
Lastbegrenzungssystem
Limitador de par



Comando a distanza
Remote control
Telecommande
Fernantrieb
Telemando



Sedile
Seat
Siege
Sitz
Asiento

Caratteristiche tecniche soggette a modifica senza preavviso.

Caracteristiques techniques sujetes a modification sans preavis

Specifications subject to change without notice.

Caracteristicas tecnicas sujetas a variacion sin previo aviso

Aenderungen ohne voranmeldung moeglich



F.lli FERRARI Corporation S.p.A - Via Pasubio,3
42022 Boretto (R.E.) - Italy
Ph.+39 - (0)522/964921
Fax +39 - (0)522/964405
E-mail: marketing@flliferrari.it